

FV50B/2 -*** (S)

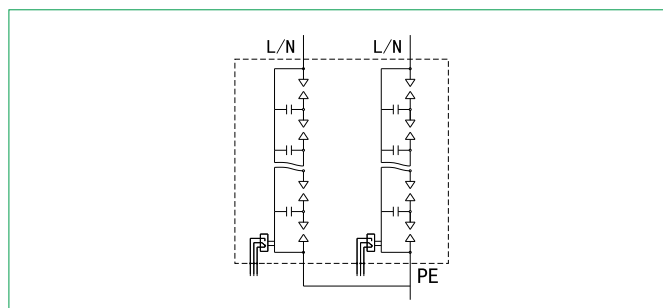

- ◆ Adopt unique designed seal construction with multilayer spark gap, no spark emission outside the housing.
- ◆ With working status indication window, and remote control contacts.
- ◆ Max.continuos operating voltage(Uc)150V~,255V~, 275V~,320V~,385V~ for your option.
- ◆ Mainly used in lightning protection zone (LPZ) 0 to 1, widely used in building entrance lines elevator, mineral, and so on.
- ◆ 1 phase,2 poles.

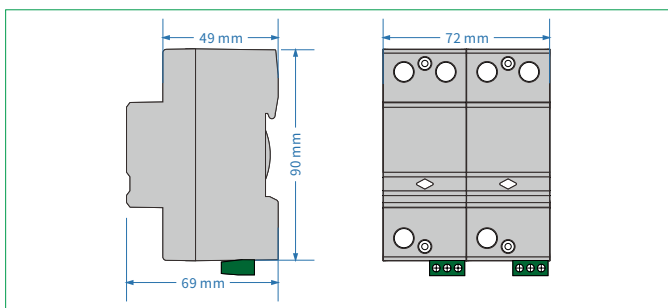

Model No.	FV50B/2-150 (S)	FV50B/2-255 (S)	FV50B/2-275 (S)	FV50B/2-320 (S)	FV50B/2-385 (S)
Test class IEC/EN/VDE	Class I/B/ <u>T1</u>				
Type of Network	TT, TN				
Protection Mode	L - PE, N - PE				
Nominal voltage 50(60)Hz U _n	110/220V~	220/380V~	220/380V~	220/380V~	220/380V~
Rated Voltage (Max. Cont. Operating Voltage) U _c	150V~	255V~	275V~	320V~	385V~
Impulse current (10/350μs) I _{imp}	50kA				
Nominal discharge current (8/20μs) I _n	50kA				
Voltage protective level U _p	≤1.8kV	≤1.8kV	≤1.8kV	≤2.0kV	≤2.0kV
Response time t _a	≤100ns				
Recommended back-up fuse	500A				
Isolation resistance	>10 ² MΩ				
I/O Connections	L-N	Multi core wire: 10mm ² ~25mm ²			
	PE	Multi core wire: >16mm ²			
Mounting	35mm Symmetrical rail (EN50022/DIN46277-3)				
Operation temperature range / humidity / altitude	-40°C~+80°C / 30%~90% / 3000m				
Degree of protection	IP20				
Housing material	UL94 V-0				
Disconnection indicator	Mechanical indicator (Green: OK, Red: replace)				
Remote control contact	Optional				

Port definition of remote control contact	Range of signal access		Recommended wire specification	
	AC	U _{max} ≤ 250V	Single core wire	Max ≤ 1.5mm ²
		I _{max} ≤ 0.5A		
	DC	U _{max} ≤ 60V	Multi core wire	Max ≤ 1.3mm ²
		I _{max} ≤ 0.1A		

Remark: if the model number is without "S", the model is without remote control contact function